

UNIBLOCK

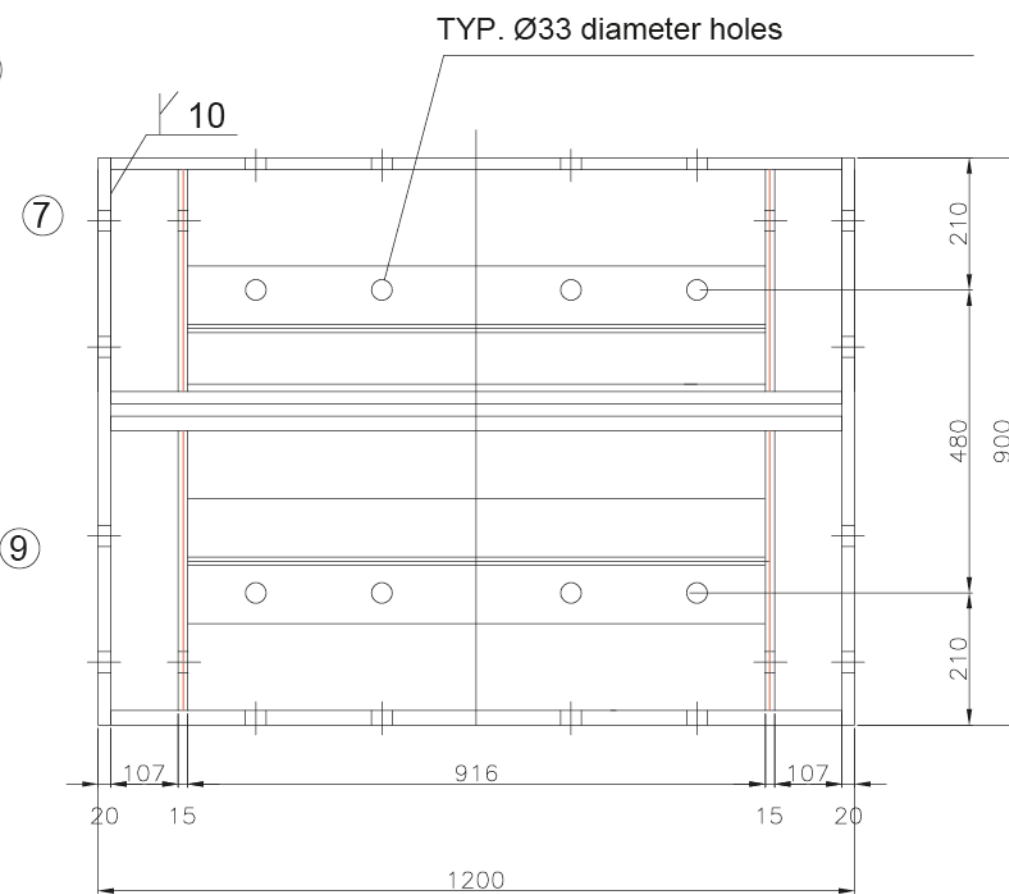
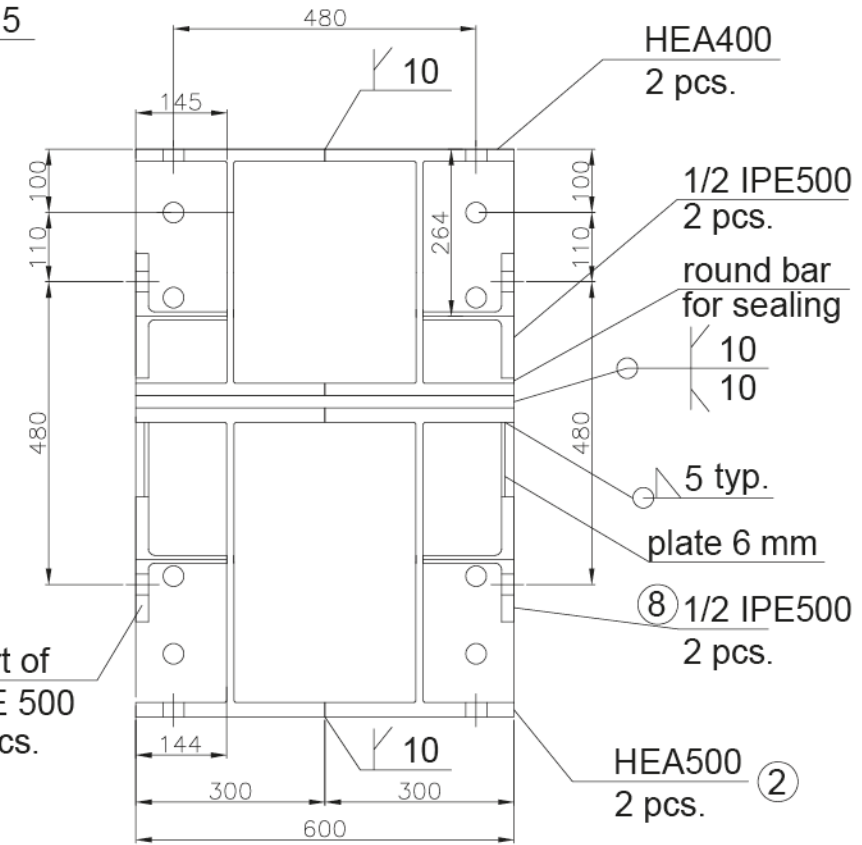
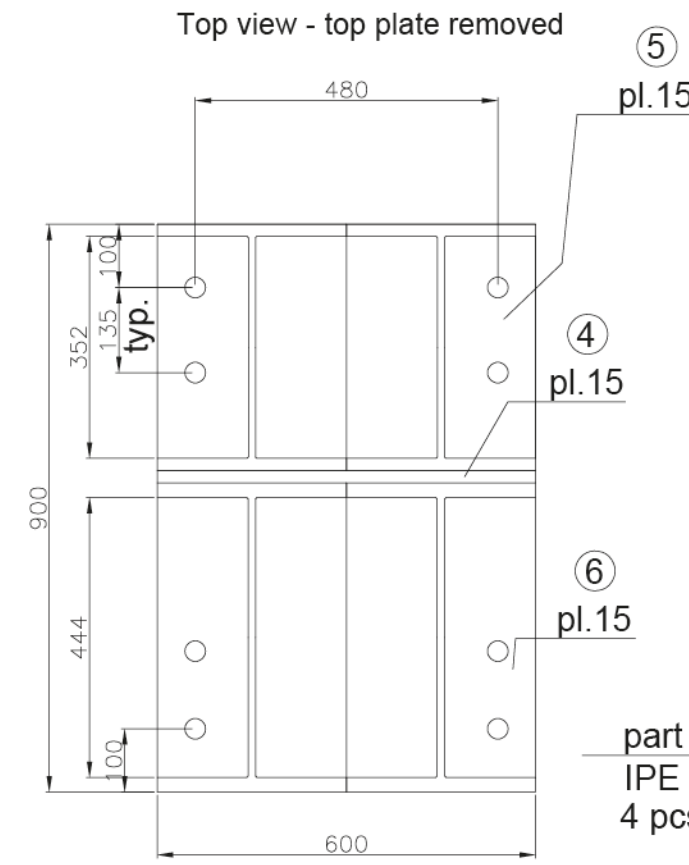
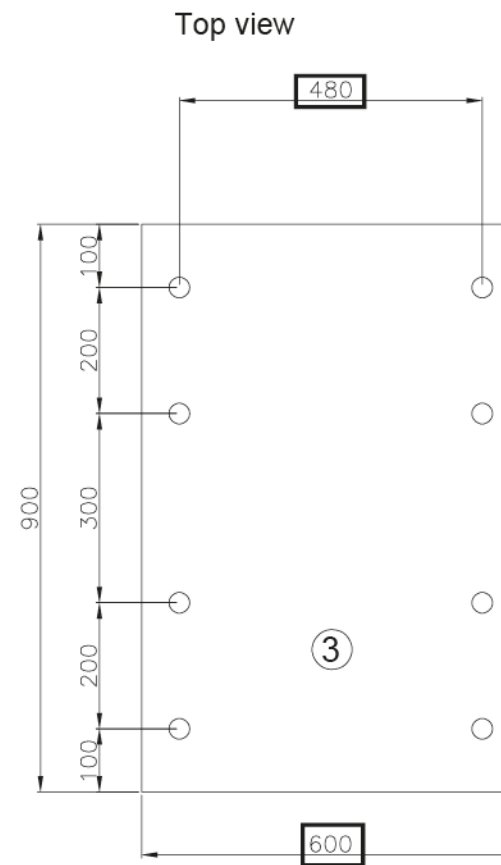
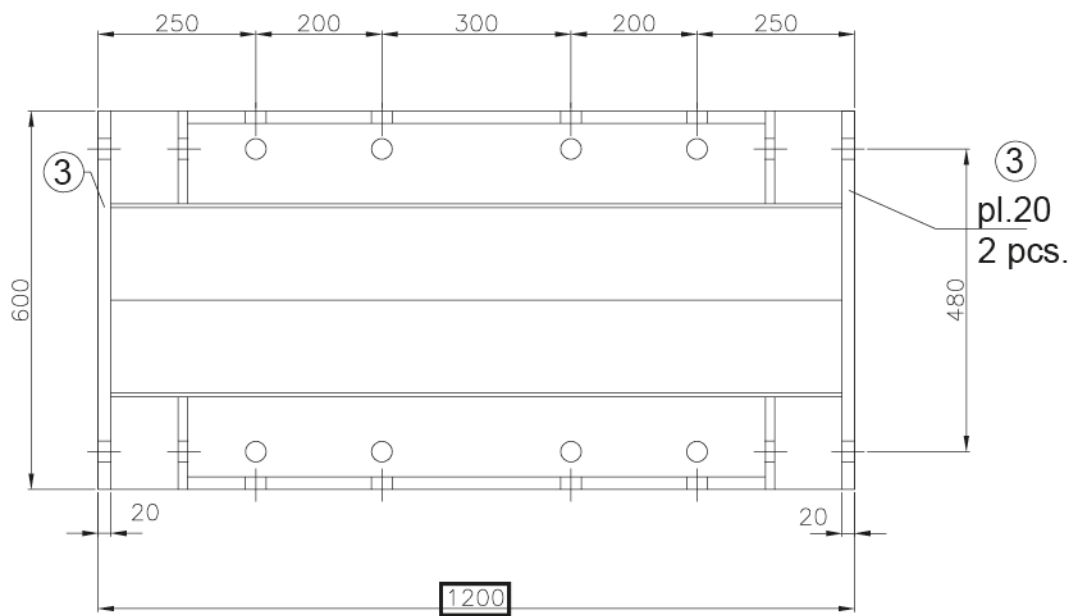

NOTES / UWAGI

- 1) All dimensions in millimetres UNO.
- 2) Material to be
Plates - min. S355J2+N
Profiles - min.S355J2+AR,
- 4) UNIBLOCKS all other welds to be 25% MPI tested.
- 5) Completed UNIBLOCKS to be shot blasted and finished with: All SIDES
green primer - NCS S0580-G30Y.
- 6) Dimensions marked in "box" are for the checking

UNIBLOCK

sheet 1/1

PREPARED: Przygotował:	CHECKED BY: Sprawdził:	Date:	Rev.
H.H.	...	2017.09.12	01